

Solid State Relay Offers More for Less: Longer Heater Life at Lower Cost



The Watlow® solid state relays (SSR) offer many of the advantages of solid state power controllers, yet at a lower cost. Watlow's extensive knowledge in power controller design has led to the development of a special fast cycle input card that enables a SSR to operate from a standard 4-20mA instrumentation command signal. Test results have shown that a zero cross SSR in combination with the fast cycle card promotes better temperature control and longer heater life than slow cycle relays. Through a time proportional cycle rate of one tenth of a second heater life will be extended.

Both low and high voltage models are available from 24 up to 530VAC. All ac output models include back to back Silicon Controlled Rectifiers (SCRs) for a more rugged design than the traditional triac based SSR. The internal design allows it to handle high currents and the harsh electrical environments of heavy industry. Watlow also offers a switched VDC model for dc heating applications.

Watlow can provide all the components necessary for trouble-free operation. This includes two standard convenience items: a thermal foil to ensure proper thermal transfer from the relay to the heat sink and belville washers that ensure the relay is mounted with sufficient pressure for good heat transfer. Matched semiconductor fuses and heat sinks are available to complete the power switching package.

Features and Benefits

Fast cycle card

- Increases heater life
- Optimizes temperature control
- Allows for higher watt density heaters

Zero cross firing

- Results in minimal electrical noise

Back-to-back SCR design

- Withstands harsh or hostile industrial environments

UL® recognized File #E151484 and #E73741

CSA certified up to 600VAC, File #LR700195

VDE 60950 License #40021401, File #1995500

up to 480VAC, CE- EN 60950 and RoHS

- Meets applications requiring agency approval

Heater Life

Watlow has extensively tested electric heating elements with a variety of power switching devices. Results prove that the life of an electric element dramatically increases when the on-off cycle time that is used to time-proportion the heater is kept at less than one second. This reduces the thermal expansion and contraction of the element and improves heater life as much as 20 times. This very fast cycle time controls temperature much more accurately and allows the use of higher watt density heating elements.

Fast Cycle Card

In order to obtain the very rapid cycling time required for longer heater life, accurate temperature control and higher watt densities, Watlow has developed a loop-powered firing card for SSRs. This card operates from a standard instrumentation signal of 4 to 20mA and controls solid state relays with a time proportional cycle rate of less than one second (4VAC cycles on and 4VAC cycles off at 50 percent power).

Thermal Transfer

A thermal foil is provided with each solid state relay for mounting on the base of the relay to improve heat transfer. In addition, two belville washers are supplied to provide the proper pressure for this transfer of heat. Use two #8-32 screws 0.625 in. (16 mm) long to secure the relay to the heat sink.

Replacing Contactors or Mercury Displacement Relays (MDRs)

Improvements in heater life and control accuracy can be achieved with SSRs operated with rapid cycle times as compared to slower operating electromechanical relays or even MDRs. When replacing these types of relays with the SSR, it is important to consider two aspects:

1. Heat

Solid state devices require a small voltage to turn on, which is consumed as heat (approx. 1.5 volts x amps = watts). This heat must be removed from the device and is usually accomplished by mounting the relay on a heat sink.

2. Failure Mode

Solid state devices should last for many years when properly protected with voltage snubbers, mounted on appropriate heat sinks and when fused with semiconductor fuses against the high currents caused by electrical shorts. Watlow's SSRs include an internal voltage snubber. However, if the unit fails, the most probable condition will be a short. Mechanical relays also have a good probability of failing short. In all cases where uncontrolled full power can cause damage, it is recommended that a high limit temperature controller and contactor be used for protection.

Wiring Diagrams

Single-Phase Fast Cycle Input Card

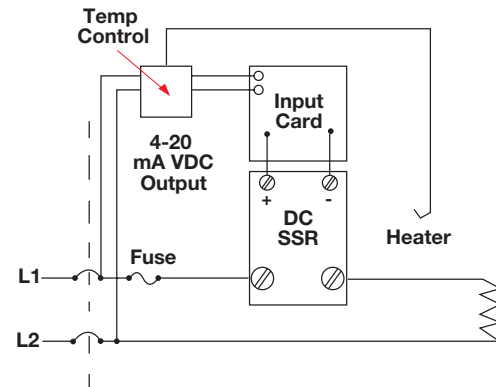

Shorted SSR Alarm

The most prevalent concern when using solid state relays is the possibility of a relay failing in a shorted condition. With this in mind, Watlow has designed a cost effective "Shorted SSR Alarm".

The device monitors the output (current through the heater) and activates a triac (alarm) if there is no command signal from the temperature controller. The triac can be wired to a bell, or to a normally closed latching relay to remove power to the heater.

The shorted SSR alarm is not a substitute for an agency-approved high-temperature limit device.

Single-Phase Shorted SSR Detector

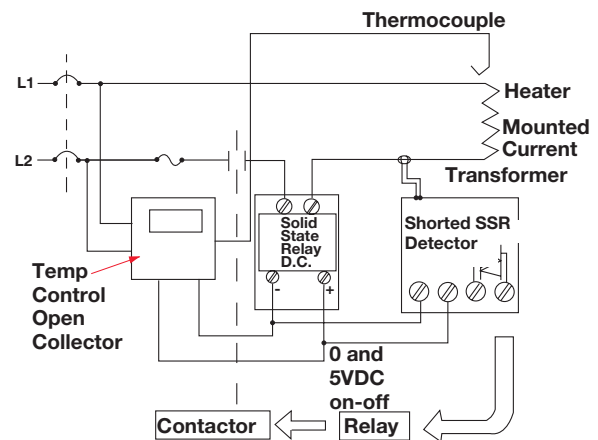

Note: Semiconductor power switching devices are not legal for over temperature limit or safety devices. For limit and safety devices you must have a positive mechanical break of all electrically hot legs simultaneously.

Dimensions - Heat Sink

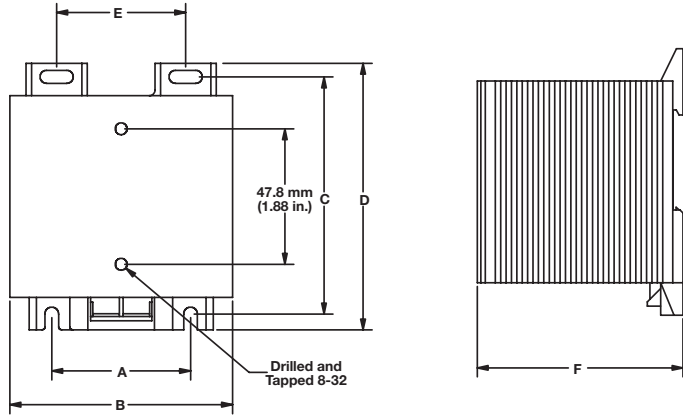

Dimensions - Solid State Relay

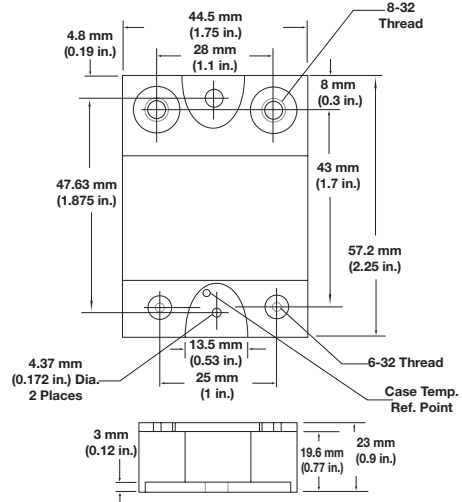

Heat Sink Dimensions by Part Number

Code Number	Descriptor	Dimensions					
		A in. (mm)	B in. (mm)	C in. (mm)	D in. (mm)	E in. (mm)	F in. (mm)
Z100-0815-000A	18A	N/A	1.8 (46)	3.25 (82.6)	3.7 (94)	N/A	1.9 (48)
Z100-0815-000B	35A	1.91 (48.5)	3.2 (81)	3.25 (82.6)	3.7 (94)	1.81 (46)	2.9 (74)
Z100-0815-000C	55A	1.89 (48)	3.2 (81)	5.45 (138.4)	5.89 (149.6)	1.81 (46)	3.6 (91)
Z100-0815-XXFC*	75A	1.89 (48)	3.2 (81)	5.45 (138.4)	7.16 (181.9)	1.81 (46)	3.6 (91)

*Fan cooled

Ordering Information

① ② ③	④ ⑤ ⑥	⑦ ⑧	⑨	⑩ ⑪ ⑫
SSR	Voltage	Current	A	Control Voltage

④ ⑤ ⑥	Voltage
100 =	0 to 100VDC (20A model with DC1 control only)
240 =	48 to 280VAC
480 =	48 to 530VAC

⑦ ⑧	Current
10 =	10A (240V models only)
20 =	20A (100VDC model only)
25 =	25A
40 =	40A (240V models only)
50 =	50A
75 =	75A

⑩ ⑪ ⑫	Control Voltage
DC1 =	3 to 32VDC (see specifications)
AC1 =	90 to 280VAC
RND =	3 to 32VDC (10A/240V, 50A/480V, 75A/480V models only)

Note: Relay will also include thermal foil, two belville washers and #32 screws for mounting to a heat sink.

Heat Sinks (sold separately)	
Z100-0815-000A =	18A or 2.2°C/watt
Z100-0815-000B =	35A or 1.1°C/watt
Z100-0815-000C =	55A or 0.6°C/watt
Z100-0815-12FC =	75A or 0.16°C/watt (120VAC fan)
Z100-0815-24FC =	75A or 0.16°C/watt (240VAC fan)

Sub Cycle Fuses - I ² T (sold separately)
Recommended and available with holders.

Watlow® is a registered trademark of Watlow Electric Manufacturing Company.
UL® is a registered trademarks of Underwriter's Laboratories, Inc.

Powered by Possibility

To be automatically connected to the nearest
North American Technical Sales Office:

1-800-WATLOW2 • www.watlow.com

International Technical Sales Offices:

Austria	+43 6244 20129 0	India	+91 40 6661 2700
China	+86 21 3532 8532	Italy	+39 02 458 8841
France	+33 1 41 32 79 70	Japan	+81 3 3518 6630
Germany	+49 7253 9400 0	Korea	+82 2 2169 2600

Mexico	+52 442 256 2200
Singapore	+65 6773 9488
Spain	+34 91 675 1292
Taiwan	+886 7 288 5168
UK	+44 115 964 0777