

Improving electric furnace heating efficiency with EPower advanced SCR controller solutions

White Paper Number HA033534 Issue 1

by Amber Watkin and Gregoire Queré

Eurotherm®

Executive summary

Electric heat treatment furnace heaters have been controlled by analog power supplies for many years. However, the demand for power factor and energy efficiency improvements, combined with CAPEX and OPEX reductions, has resulted in the need for more cost efficient solutions.

Developments in digital SCR control technologies have led to the design of the EPower™ Advanced SCR controller. Significant efficiency and cost benefits can now be gained by installing an intelligent EPower controlled power supply solution.

Introduction

The accuracy and repeatable performance of an electric heat treatment furnace is dependent on the control of key process parameters, such as temperature, atmosphere, pressure, and electrical energy delivered to the heaters. The temperature inside the furnace is typically controlled by either a temperature or process controller, a programmable logic controller (PLC), or by manual adjustments coupled with an electrical power actuator.

Historically, analog power control devices or strategies have been used to control the electrical power delivered to these furnaces. Examples of analog control devices include a variable reactance transformer (VRT), a saturable-core reactor, and an analog silicon-controlled rectifier (SCR).

Both the VRT and the saturable core reactor types use analog SCR-driven direct current (DC) control windings to indirectly regulate the output power from the secondary winding of the transformer to the heating elements. Variation of power in the VRT is managed by applying DC to the control winding, which saturates or desaturates the VRT core.

These types of analog power supplies perform well during the initial heating of the furnace when the output is 100%. However, during the heat treatment cycle when output levels are below 100%, a significant reduction in the power factor, energy efficiency and process performance occurs. This leads to unnecessarily high energy costs and variations in workpiece quality.

For the past 50 years, analog based designs have served the industry well. However, the demand for cost effective solutions that can improve energy efficiency, power factor, temperature accuracy, workpiece quality, equipment reliability, and process repeatability, has led to developments in digital SCR control technologies.

The EPower Advanced SCR Controller enables the design of intelligent digital SCR power control solutions that offer significant cost and efficiency benefits. The combination of increased performance and energy efficiency helps machine builders and heat treaters meet their new customer challenges, by achieving a higher power factor and lowering operational costs. This white paper reviews some of the key benefits of power supply and VRT designs.

Legacy analog design

In the VRT design, there is no direct proportional link between the power output delivered to the heating element and the setpoint delivered by the temperature controller to the DC voltage control.

Figure 1

In a VRT power supply, the output current varies by the level of DC flowing through its control winding.

The DC is sourced from a proportionally-driven (4-20mA) analog SCR power controller.

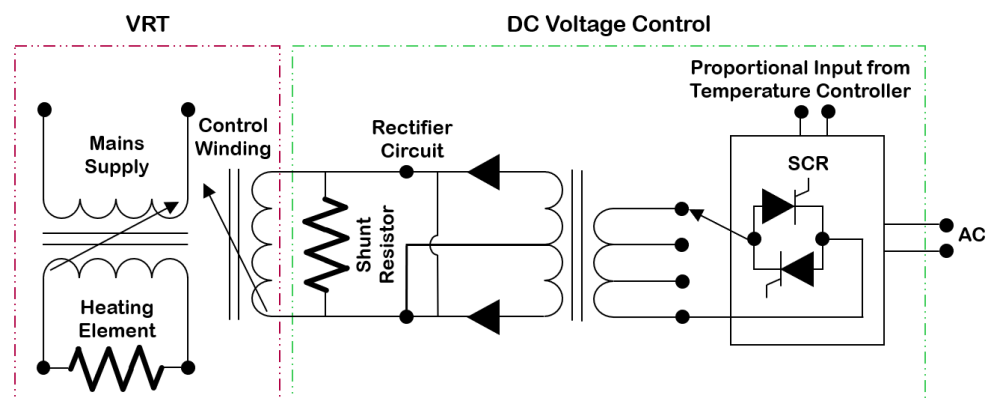

The analog SCR parameter settings, such as control loop response, current limit setpoint, and ramp duration, need to be preset at factory level, typically by use of potentiometers and capacitors. As these devices are affected by age and temperature, the settings often drift over time, leading to changes in power control behavior. The result is unstable control and poor temperature accuracy.

An analog SCR controlled power supply is also an open-loop design with no link between the power output and the setpoint delivered to the SCR by the temperature controller. The analog SCR power controller also suffers from parameter drift, leading to the same temperature instabilities as the VRT.

Figure 2

In a typical legacy SCR controlled supply, an analog SCR power controller is directly coupled to the primary or secondary winding of a power transformer.

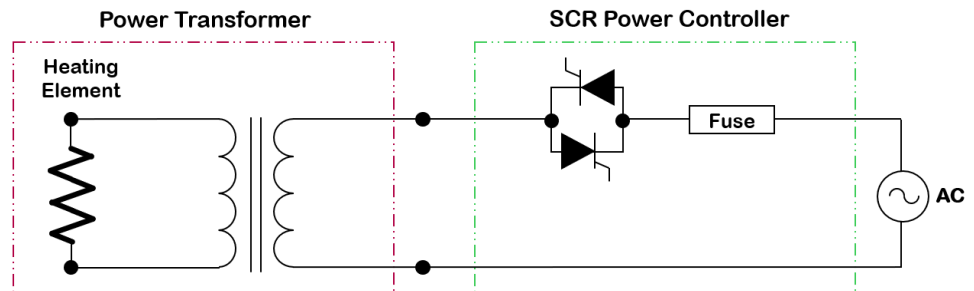

Data driven performance

Advanced power control technology in the Eurotherm EPower SCR Power Controller can enable improvements in furnace performance, productivity, workpiece quality, and energy consumption.

Benefits of advanced digital SCR control

The EPower advanced digital SCR is the core building block of an intelligent SCR power supply. Its digital design offers the capabilities of a microcontroller, including the latest Ethernet communications, combined with adjustable advanced I/O strategy implementation and management.

Figure 3

An EPower advanced SCR controlled power supply has access to data, enabling better control of parameters for improved energy efficiency.

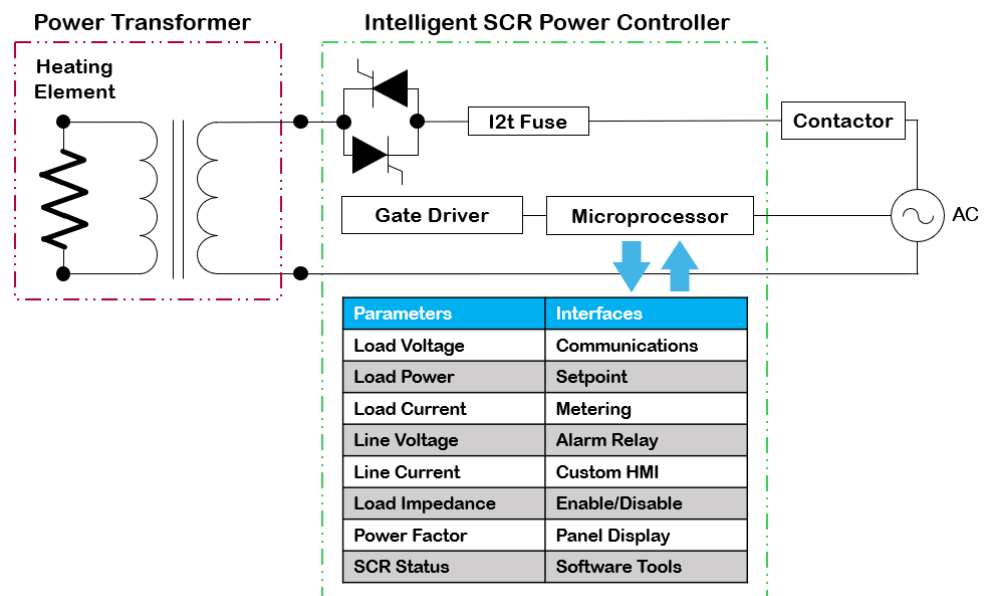

Unlike analog designs, the EPower controller's parameters are flexible and can be customized to suit a particular application. Proprietary algorithms and user-definable configurations are embedded in the microcontroller and can be stored, recalled, and modified as needed. Energy efficient hybrid firing modes, nominal values, limits, alarms, math functions, logic, and I/O configurations can be defined via menu selection or be built using a PC based function block editor, similar to those used in PLCs. An Ethernet port provides direct access to

configurations, diagnostics, and process data previously unavailable in analog designs.

As the EPower device is a digital SCR controller, its factory-set calibration and control parameters are digitally set. Therefore, they are considerably less able to drift compared to analog SCR controllers. Digital ramp durations and thresholds, which can be set up in the graphical wiring strategy, offer better power control response compared to analog SCRs, and therefore provide improved process repeatability.

Accurate and repeatable closed loop power output control is provided through selectable control modes, such as voltage, current, power, impedance, or a hybrid combination of firing modes, to address the physical property responses of particular types of heating elements.

Power factor improvements using hybrid firing modes

Hybrid firing mode techniques and automatic transformer tap selection technology (load tap changing) help to maintain a high energy efficiency compared to legacy analog designs. With advanced SCR technology, a power factor better than 0.9 can be achieved across the entire power curve. Advanced power control also helps to minimize the effect of mains voltage fluctuations and variations in load impedance within the temperature process control.

Digital power control allows precise duplication of parameters resulting in repeatable process behavior and workpiece quality. **Figure 4** shows how an EPower controlled power supply distributes power to the heating elements of a multizone furnace. Configurable function blocks in the EPower controller allow the setpoint of each zone to be offset, to compensate for zone temperature variations.

Figure 4

In a multizone vacuum furnace, the combination of an EPower advanced SCR controller, Ethernet-capable PLC, and power transformer, enables the supply of energy-efficient, correctly distributed power to the furnace heating elements.

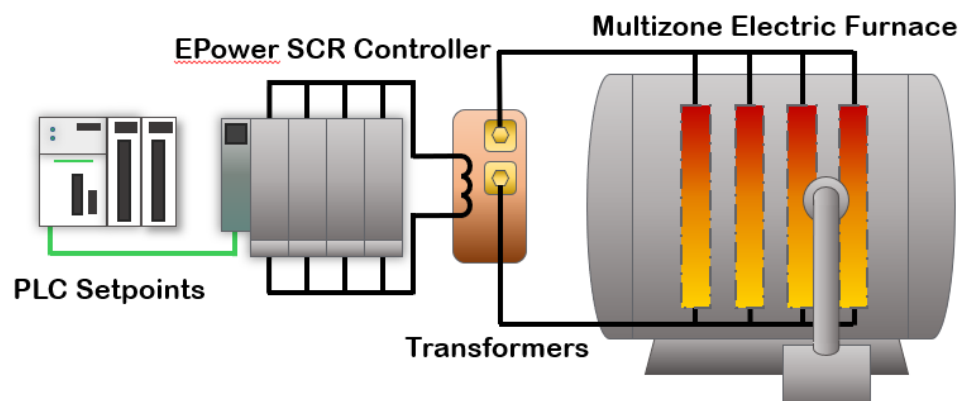

Benefits of communication technologies

Fast Ethernet communications allow custom configuration and monitoring of electrical process measurements, such as load impedance, power factor, voltage, current, energy, and power to aid diagnostics. This helps to facilitate product implementation into the control architecture, reduce downtime, and improve overall process performance.

Available communication protocol options include Modbus TCP, EtherNet/IP, and PROFINET. Ethernet communications provide a direct link between the EPower SCR controlled power supply and higher level control, including temperature controllers, HMIs (Human Machine Interface), PLCs, SCADA (Supervisory Control and Data Acquisition), or IIoT (Industrial Internet of Things) enabled technologies.

Improved reliability

Although analog power supplies have been used in furnace applications for decades, when replacing them with advanced SCR technology, addressing some key considerations can improve the overall reliability of the power supply. For example, as with all custom designs, special consideration needs to be given to the installation environment. In dusty, corrosive, or humid environments the power and control electronics need to be housed in enclosures with the appropriate NEMA or IP protection rating.

Adequate cooling is also vitally important. Typically, the PLC, HMI, SCR, and other digital controls are installed on the control-side of a compartmentalized enclosure. The air or water-cooled transformer and its tap connections, switches, or other power connections are installed on the power-side. This separation also provides protection against electrical interference. Often, a custom designed EPower controlled SCR power supply can be installed in a footprint much smaller than a VRT design.

Better robustness through monitoring and alarms

The reliability of an intelligent EPower SCR power supply lies not only in its design but also in its advanced diagnostics that monitor the condition of heating elements. Condition monitoring helps reduce unplanned downtime due to an unexpected breakdown of an element. The EPower controller can monitor the characteristic impedance of a heating element across its operating temperatures and/or known life cycle. As the heating element approaches its end of life, the total load impedance increases and the setpoint eventually becomes unreachable, triggering an alarm. The EPower controller can detect these conditions and notify the operator in advance, allowing enough time to order replacement parts and schedule maintenance.

Full or partial load alarms work in a similar manner. The impedance characteristic of the load under normal conditions is measured and stored. If a series or parallel element is unexpectedly lost from the load circuit, the impedance increases by a known percentage. If the impedance increases beyond that percentage threshold an alarm is triggered. If in constant power mode, the EPower controller continues to precisely regulate output power within user-defined voltage and current limits, thus compensating for the lost heating element.

Other useful alarms include indication of load imbalance, voltage/current/power limitation, over temperature, low or high line voltage, short or open circuit SCR, and unreachable power output.

Lower energy costs

Energy efficiency is expressed in terms of power factor, which ranges between 0 and 1. EPower controlled power supplies reduce energy costs by employing power factor improvement techniques through hybrid firing. Hybrid firing modes produce much better power factors than analog designs. Additionally, peak power demand can be managed to help avoid demand charge penalties from the energy supplier. In many cases, the resulting energy savings can provide a payback in as little as two years (depending upon local energy rates).

Improving energy efficiency

As mentioned, unregulated analog power supplies are sensitive to changes in supply voltage or load impedance. For instance, the resistivity of a SiC (silicon carbide) heating element changes significantly during its transition from cold to nominal operating temperature (approximately 1000°C), as well as due to the ageing effect. The ageing effect can increase the resistance by up to 300% over the life of the SiC heating element. These variations in resistance greatly

compromise the performance of analog power supplies, resulting in poor process regulation and higher energy costs due to low power factor and high THDi (total harmonic distortion in current).

MoSi₂ (molybdenum disilicide) based heating elements also have a significant resistance variation (up to x10) between hot and cold temperatures. Therefore, current limitation is necessary to avoid damage to the elements or power supply. Intelligent EPower controlled power supplies are designed to address resistance variations while maintaining optimal energy efficiency with high power factor, thanks to the hybrid control mode.

For example, in a typical MoSi₂ heating application, the EPower controller can be configured in a PC based function block editor to perform hybrid firing, which limits transformer magnetization and cold element inrush currents. As shown in **Figure 5**, the EPower controlled power supply first ramps the output towards the setpoint using phase angle firing mode with current limit. Unlike a fixed current limit, this proportional current transfer mode is linear and follows the output as a percentage of the setpoint. As the impedance of the MoSi₂ heating element increases with temperature, the SCR output also increases. The EPower controller automatically transfers from current limitation mode to zero-cross firing mode (also known as burst firing) with power regulation, to optimize the energy efficiency.

Figure 5

Example waveform showing EPower controller hybrid firing into a MoSi₂ heating element.

Hybrid firing provides better control that can extend heating element life and improve overall energy efficiency.

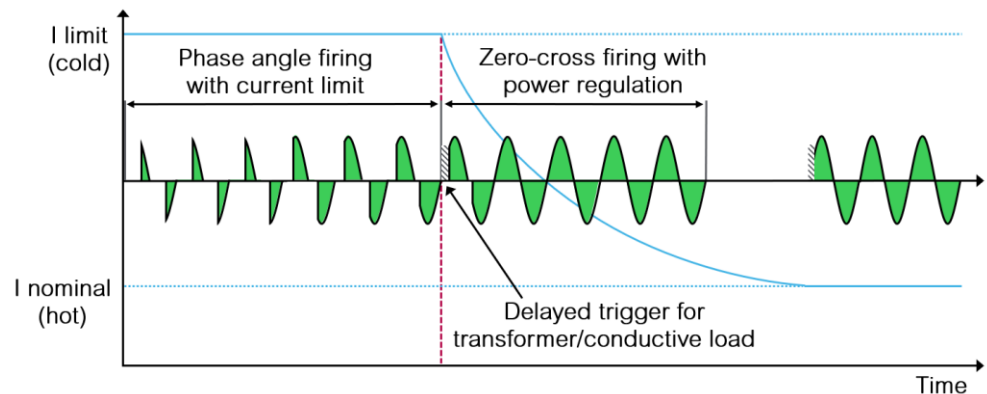

Optimizing energy usage with predictive load management

Once the EPower SCR controller is in energy efficient zero-cross firing mode, the on/off times for each zone may be managed through distributive load management algorithms, within the predictive load management feature. The load sharing feature shown in **Figure 6**, intelligently controls zone firing times to be time proportioned and evenly distributed, smoothing the power demand. This feature helps to stabilize the power consumption on the main distribution board or cubicle, improving the efficiency of a multizone application or furnace.

Figure 6

Unmanaged heating zones can switch on at the same time resulting in huge power demand variation.

Load sharing in EPower predictive load management, balances demand by switching heater zones on at different times in the modulation period.

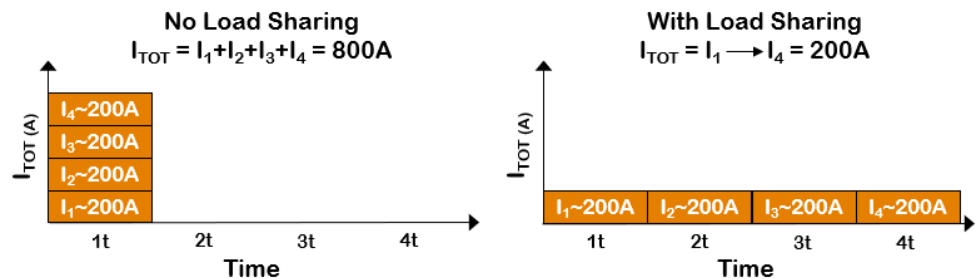

In cases where multiple furnaces operate in the same plant, the load shedding feature can be employed to limit the overall power demand of the furnaces within the tariff band of an agreed energy contract. This helps to avoid peak power demand charge penalties. The power shedding threshold can be controlled

dynamically. Special care needs to be taken so that the limitations do not interfere with the process integrity.

Figure 7

With no load shedding peak power demand is exceeded, leading to penalties.

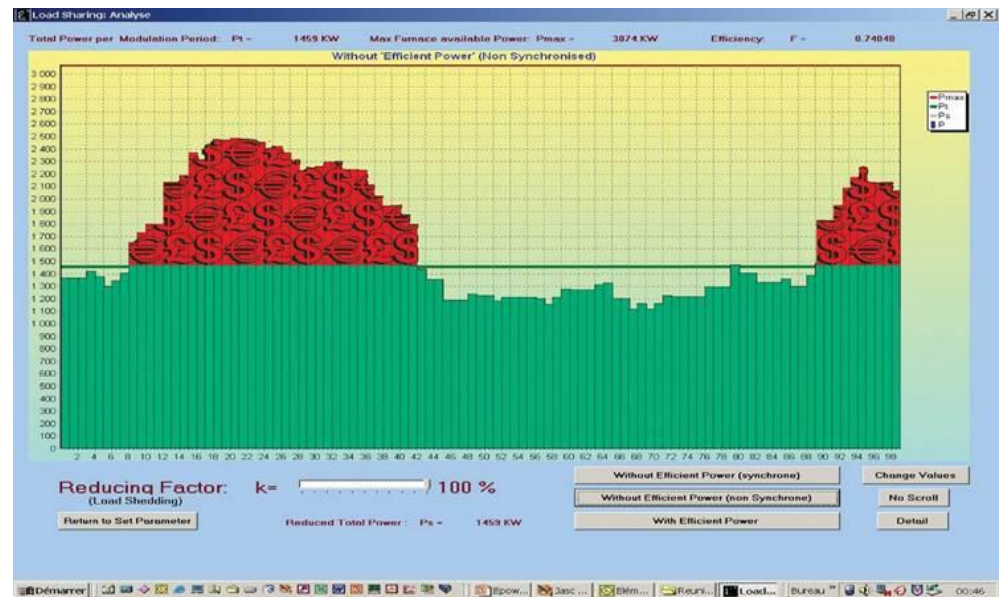

With load shedding enabled, peak power demand can be kept under control.

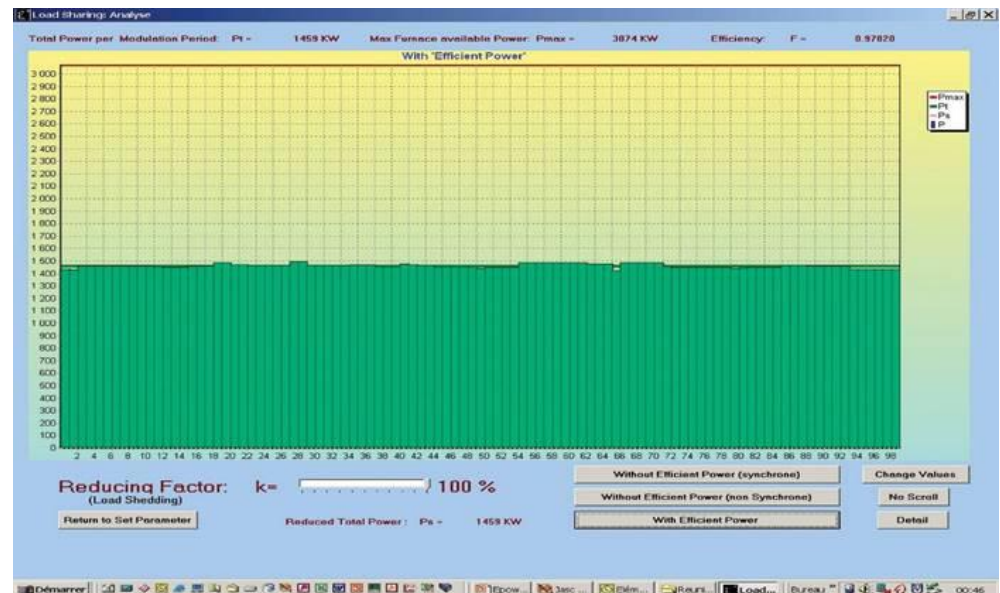

Predictive load management can also help to maximize plant capacity by keeping the power demand from feeder transformers, switchgear, and conductors to a limit, as well as helping to reduce power brownouts and voltage flicker.

Figure 8

Predictive load management in the EPower controller uses load sharing and load shedding techniques to balance and limit peak power demand across the plant.

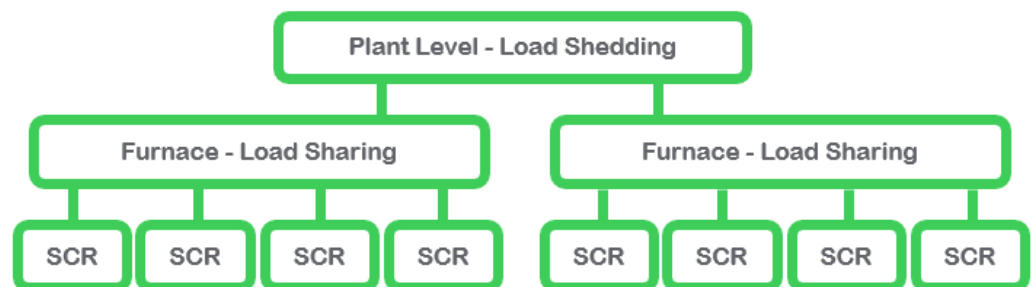

Conclusion

The argument for moving to intelligent power supplies in electric furnace heating applications is compelling. Increased competition and demand for tighter process control has placed a stronger emphasis on improving power factor, reducing unplanned downtime, lowering costs, and improving workpiece quality. Analog designs are no longer adequate to meet these needs. Developments in the EPower advanced power controller have enabled the design of intelligent power supply solutions which have significant advantages over traditional analog power supplies. Higher reliability, through ruggedized designs and advanced diagnostics, extends beyond the power supply to include condition monitoring of heating elements. Both the initial investment and operating costs of intelligent power supplies based on the EPower SCR controller are significantly lower than analog designs. With improvements that can achieve a power factor of >0.9 combined with energy saving features, payback periods can be as little as two years. Intelligent power supply technology also adds flexibility, connectivity, and data management capability to meet today's unrelenting demand for tighter quality control and higher productivity.

About the author

Amber Watkin is an Application Marketing Engineer at Eurotherm by Schneider Electric. With over 25 years' experience in the Eurotherm portfolio, she covers Glass, Heat Treatment, Semiconductor, Life Science, and Food and Beverage industries. She is responsible for promoting Eurotherm energy saving, efficiency enhancing solutions and services, designed for energy intensive, high performance, specialized and regulated thermal processing applications.

About the author

Gregoire Queré is Global Power Solutions Business Development Manager at Eurotherm by Schneider Electric.

Eurotherm Limited
Faraday Close, Worthing
West Sussex BN13 3PL
United Kingdom
Phone: +44 (0) 1903 268500

www.eurotherm.com